



WBS 1.08.03 L3

Observatory DAQ:

Interface to Data Management

L3 co-Lead - Alexandra Rahlin

CQ2

Presenter Background

Name: Alexandra (Sasha) Rahlin

Role: L3 1.08.03 Observatory DAQ co-lead (w/ Abby Crites)

Institution: University of Chicago / Fermilab

Discipline: Cosmology instrumentation

Previous experience:

- Integrated much of the in-flight control and computing software/hardware for the SPIDER balloon-borne instrument (PhD thesis project, 8 years)
- Data analysis / software development lead for SPT-3G (4 years)
- SPT Winterover Technician for 2021 winter season, working on streamlining realtime data analysis and data transfer systems, which inform much of the site computing and data movement work for CMB-S4



Overview

Collate DAQ data into packaged data products

Coordinate with Data Management for registration, storage and transfer

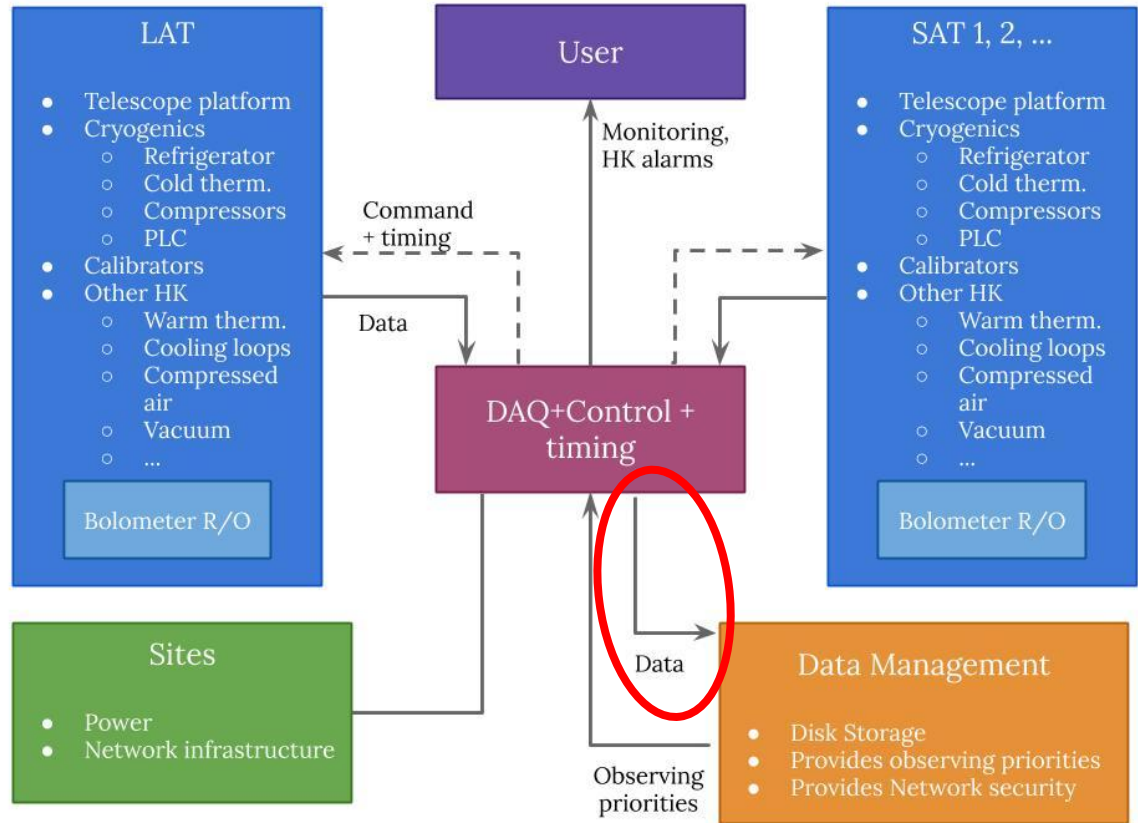

Key Contributors

Data Management / Site Hardware (1.09.07) co-leads Tom Crawford and Sasha Rahlin

- On-site data storage

Data Management / Data Movement (1.09.02)

- Data registration and transfer off-site

Abby Crites (co-lead this L3)

- Telescope + Bolometer readout

Chris Weaver (Michigan State U.)

- Software engineering

Description of L4 WBSs

Lvl 2	Lvl 3	Lvl 4	
1.08 Observatory Control and Data Acquisition Systems	1.08.01 - DAQ Management	1.08.01.01 - DAQ Management	
		1.08.01.02 - DAQ System Design Engineering	
		1.08.01.03 - DAQ Reviews	
		1.08.01.04 - Interface Documentation	
		1.08.01.05 - Specification Tracking	
		1.08.01.06 - DAQ Milestones	
		1.08.01 - Observatory Control System	1.08.02.01 - Bolometer Readout Control
			1.08.02.02 - Telescope Platform Control - SP, Chile, LAT, SAT
	1.08.02.03 - Cryogenic Control		
	1.08.02.04 - Housekeeping Control		
	1.08.02.05 - Observatory Subsystem Control		
	1.08.02.06 - Build/Distribution System (Control System)		
	1.08.02.07 - Scheduling		
	1.08.02.08 - Control Framework		
	1.08.03 - Observatory Data Acquisition	1.08.03.01 - Bolometer Readout	
		1.08.03.02 - Telescope Readout Data Acquisition	
		1.08.03.03 - Housekeeping Data Acquisition	
		1.08.03.04 - Observatory DAQ Network Design	
		1.08.03.05 - Hardware Procurement	
		1.08.03.06 - Timing	
		1.08.03.07 - DAQ Build/Distribution	
		1.08.03.08 - File Format Specification	
	1.08.04 - Monitoring and Alarms	1.08.04.01 - Remote Monitoring Capability of Telescope, Housekeeping Subsystems	
		1.08.04.02 - Remote Monitoring and Real-Time Statistics Gathering	
1.08.04.03 - Non-Critical Alarms based on Bolometer + HK Monitors			
1.08.04.04 - Personnel and Equipment Protection Interfaces Propogated to Alarms			
1.08.04.05 - Personal Protection (PPE) Interfaces			
1.08.05 - Subsystem Development and Support			
1.08.06 - Deployment of DAQ and OCS			

Key Driving Requirements

CQ1

Data Description: Include all data and metadata necessary for analysis of the survey data

Data Rate: Expect 83 Mbps / SAT, 1.7Gbps / SAT, processed in real time

Data Loss: <0.001%, data integrity checks integrated with IO in software

Data Format: Interface with Data Management to define data format for packaged survey data products

ID	Name
CMBS4-SET-86	DAQ Subsystem Requirements (Level 2)
CMBS4-FLD-78	DAQ Data Subsystem Requirements (Level 2)
CMBS4-DAQ_DATA-49	Data Description
CMBS4-DAQ_DATA-50	Data Rate
CMBS4-DAQ_DATA-51	Data Loss
CMBS4-DAQ_DATA-52	Data format
CMBS4-DAQ_DATA-53	Timing
CMBS4-DAQ_DATA-54	Time Stamp
CMBS4-DAQ_DATA-55	Health & Monitoring
CMBS4-DAQ_DATA-57	Alarms
CMBS4-DAQ_DATA-59	Error trace/logs
CMBS4-DAQ_DATA-60	Network
CMBS4-DAQ_DATA-63	Synchronicity
CMBS4-DAQ_DATA-64	Health and Monitoring
CMBS4-DAQ_DATA-67	Timing
CMBS4-DAQ_DATA-68	Monitoring
CMBS4-DAQ_DATA-69	Meta-data

Interfaces

CQ2

Interface with Data Management / Data Movement (1.09.02) to define an appropriate file format for packaged data products, and integration with registration and data transfer system they provide

Interface with Data Management / Site Hardware (1.09.07) for storing packaged data products on-site

Interface with other Observatory DAQ (1.08.03) components for collecting and processing raw data into the appropriate data format

Interface with Lab Support (1.08.05), and Integration, Deployment (1.08.06) for prototyping and deployment

Technical Design: High-Rate DAQ

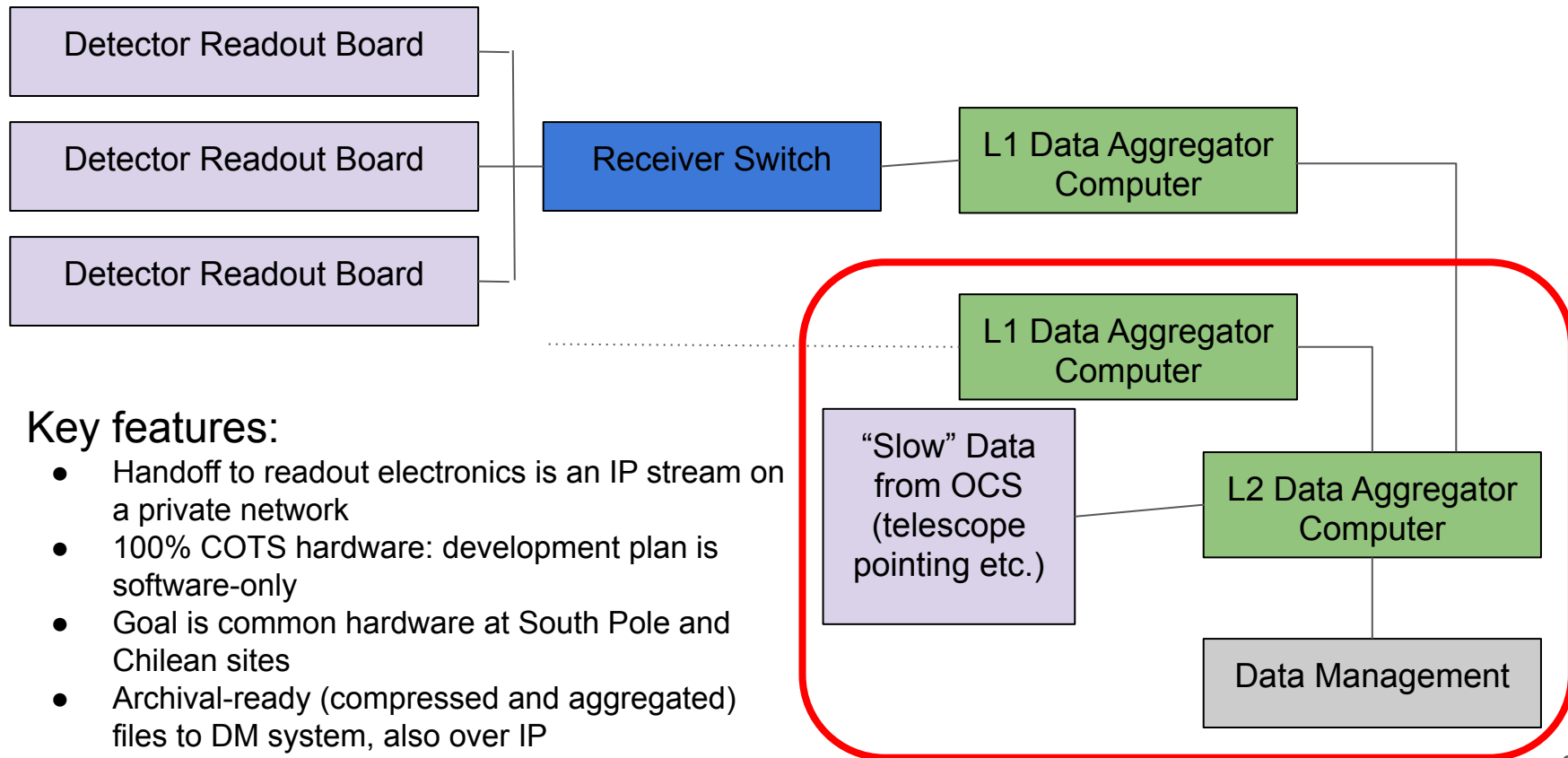

Key features:

- Handoff to readout electronics is an IP stream on a private network
- 100% COTS hardware: development plan is software-only
- Goal is common hardware at South Pole and Chilean sites
- Archival-ready (compressed and aggregated) files to DM system, also over IP

Technical Design: Raw Data

- Use frame structure from spt3g_software (heritage: designed for SPT-3G, conceptually similar to IceCube IceTray)
- Raw data streamed in “Timepoint” frames containing one sample per bolometer
- Prefaced with relevant housekeeping data (channel wiring map, nominal calibration parameters, etc)
- Temporarily written to buffer disk space prior to packaging

Example from SPT-3G (fmux)

```
Frame (Wiring) [  
  "ReadoutSystem" (spt3g.core.G3String) => "ICE"  
  "WiringMap" (spt3g.dfmux.DfMuxWiringMap) => 14112 elements  
]  
Frame (Calibration) [  
  "DfMuxTransferFunction" (spt3g.core.G3String) => "spt3g_filtering_2017_f  
  "NominalBolometerProperties" (spt3g.calibration.BolometerPropertiesMap)  
]  
Frame (Housekeeping) [  
  "DfMuxHousekeeping" (spt3g.dfmux.DfMuxHousekeepingMap) => 30 elements  
]  
Frame (Timepoint) [  
  "CalibratorOn" (spt3g.core.G3Double) => 1  
  "DfMux" (spt3g.dfmux.DfMuxMetaSample) => 30 boards, with 240 modules  
  "EventHeader" (spt3g.core.G3Time) => 07-Jun-2021:21:55:16.278230360  
]  
Frame (Timepoint) [  
  "CalibratorOn" (spt3g.core.G3Double) => 1  
  "DfMux" (spt3g.dfmux.DfMuxMetaSample) => 30 boards, with 240 modules  
  "EventHeader" (spt3g.core.G3Time) => 07-Jun-2021:21:55:16.284783960  
]
```

Technical Design: Compression

- Collect Timepoint frames in to “Scan” frames in realtime, integrated with relevant telescope housekeeping data (pointing, readout, calibration, etc)
- Timestreams compressed using FLAC lossless algorithm (expect 4x compression)
- Split frames at scan edges (e.g. turnarounds)
- Record observation parameters in header frame once the observation is complete
- Requires O(1) processor and 2-4 GB of RAM per 10K channels.

```
Frame (Observation) [  
  "BenchCommandedPosition" (spt3g.core.G3MapDouble) => 6 elements  
  "BenchZeros" (spt3g.core.G3MapDouble) => 6 elements  
  "ObservationID" (spt3g.core.G3Int) => 139942164  
  "ObservationStart" (spt3g.core.G3Time) => 08-Jun-2021:16:49:25.000000000  
  "ObservationStop" (spt3g.core.G3Time) => 08-Jun-2021:18:57:13.000000000  
  "SourceName" (spt3g.core.G3String) => "ra0hdec-44.75"  
]  
Frame (PipelineInfo) [  
  "08-Jun-2021:10:10:49.952401000" (spt3g.core.G3PipelineInfo) => master branch, local diffs  
  "08-Jun-2021:20:18:04.199295000" (spt3g.core.G3PipelineInfo) => master branch, local diffs  
]  
Frame (Wiring) [  
  "ReadoutSystem" (spt3g.core.G3String) => "ICE"  
  "WiringMap" (spt3g.dfmux.DfMuxWiringMap) => 14112 elements  
]  
Frame (Scan) [  
  "ACUStatus" (spt3g.gcp.ACUStatusVector) => [Az 202.612 deg, el 40.814 deg at 08-Jun-2021:16:49:26.00  
  , el 40.814 deg at 08-Jun-2021:16:49:27.000000000, TRACKING, Az 202.882 deg, el 40.9113 deg at 08-Ju  
  NG, Az 203.732 deg, el 40.9165 deg at 08-Jun-2021:16:49:29.000000000, TRACKING]  
  "BenchPosition" (spt3g.core.G3TimestreamMap) => Timestreams from 6 detectors  
  "CalibratorOn" (spt3g.core.G3Timestream) => 577 samples at 152.6 Hz  
  "DetectorSampleTimes" (spt3g.core.G3VectorTime) => 577 elements  
  "DfMuxHousekeeping" (spt3g.dfmux.DfMuxHousekeepingMap) => 30 elements  
  "GCPFeatureBits" (spt3g.core.G3VectorString) => [analyze]  
  "ObservationID" (spt3g.core.G3Int) => 139942164  
  "OnlineBoresightAz" (spt3g.core.G3Timestream) => 577 samples at 152.6 Hz  
  "OnlineBoresightDec" (spt3g.core.G3Timestream) => 577 samples at 152.6 Hz  
  "OnlineBoresightEL" (spt3g.core.G3Timestream) => 577 samples at 152.6 Hz  
  "OnlineBoresightRa" (spt3g.core.G3Timestream) => 577 samples at 152.6 Hz  
  "OnlinePointingModel" (spt3g.core.G3MapVectorDouble) => {fixedCollimation, flexure, tilts, time, }  
  "OnlineRaDecRotation" (spt3g.core.G3TimestreamQuat) => 577 quaternions at 152.6 Hz  
  "RawBoresightAz" (spt3g.core.G3Timestream) => 577 samples at 152.6 Hz  
  "RawBoresightEL" (spt3g.core.G3Timestream) => 577 samples at 152.6 Hz  
  "RawTimestreams_I" (spt3g.core.G3TimestreamMap) => Timestreams from 14112 detectors  
  "RawTimestreams_Q" (spt3g.core.G3TimestreamMap) => Timestreams from 14112 detectors  
  "SourceName" (spt3g.core.G3String) => "ra0hdec-44.75"  
  "TrackerPointing" (spt3g.gcp.TrackerPointing) => 400 tracker pointing samples from 08-Jun-2021:16:49:  
  9:29.000000000  
  "TrackerStatus" (spt3g.gcp.TrackerStatus) => 400 tracker samples from 08-Jun-2021:16:49:25.010000000  
  0  
  "Turnaround" (spt3g.core.G3Bool) => True  
]
```

Technical Design: Computing Resources

- Computing resources for packaging and compression provided by DAQ
 - Two machines for redundancy in event of hardware failure
 - 24 cores, 100 GB RAM, 50 TB scratch disk space
- Transfer final data products to storage disks on site provided by DM Site Hardware (1.09.07)
 - 420 TB storage server in Chile for up to 1 month of data
 - 4 PB storage server at South Pole for 1 year of data
- Register data products with data movement database (1.09.02) using a provided API

Prototyping Plans

Exercise the acquisition/compression algorithms in laboratory testing, and at scale (e.g. with synthesized data)

Interface with Data Management team to integrate with their data registration system as part of the pre-commissioning “Data Challenge” process

Data compression and storage to be ready for pre-deployment, alongside South Pole prototype computing hardware, final tests will happen during DC4 (one year prior to deployment)

DAQ streaming and compression algorithms already in use by SPT-3G

Conclusions

Team has extensive experience with data acquisition systems for CMB data, particularly with the spt3g_software package to be used.

Strong engagement with Data Management L3 (1.09) and with Lab Support (1.08.05) and Integration (1.08.06) L3's necessary to create a robust interface for providing final data products to the rest of the S4 collaboration.

The data processing software is mature and currently in use by SPT-3G, requires straightforward effort to integrate with the CMB-S4 DAQ system and data products.

Next steps:

- Define the format to be used for packaged data (frame contents, etc)
- Prototype data packaging framework in the lab
- Test packaging framework at scale, with synthesized data if necessary